

# ***POWERLINE***

## **HEAVY DUTY ISOLATORS**

**MODELS: 22-2, 22-6, 22-8, 22-17, 22-24, 22-26, 22-44**

### **CONGRATULATIONS!**

...for choosing this high quality **POWERLINE** PRODUCT. The latest state of the art engineering plus years of experience have gone into each **POWERLINE** product.

The attached instructions are provided to assist you with step by step installation. Test procedures are also provided to be kept with your equipment should future reference be desired.

Every effort has been made to use the finest materials and workmanship. In the event that service is ever needed or you have questions regarding the product, installation or performance please give us a call.

Your Friends at the factory

### **AN ISO 9001 COMPANY**

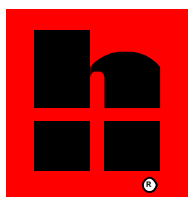

# **HEHR**

# ***POWER SYSTEMS***

A DIVISION OF HEHR INTERNATIONAL INC.

4616 Fairlane Avenue, Ft. Worth, TX 76119

817.535.0284 • fax: 817.531.2755 • Canada: 905.852.5417

E-Mail: [sales@hehrpowersystems.com](mailto:sales@hehrpowersystems.com)

FORM 05080 MBJ 06/99

## POWERLINE

Heavy Duty

Isolators

Isolators for Motorola Alternators  
Except Load Handier Series  
Models: 22-2,22-6,22-8,22-17,22-24,22-26,22-44

### Installation Instructions

1. Prior to starting Isolator installation, take the following voltage readings.
  - A. Start Engine. Run at fast idle.
  - B. Measure the voltage at the output terminal of the alternator. This should be about 14 volts.
  - C. Measure the voltage at the "REG" Terminal of the alternator (This is the small red wire that runs to the regulator)
2. Disconnect Negative cable from battery.
3. Mount isolator in location away from maximum Engine heat and in a location that will let the isolator receive maximum airflow.
4. Remove all wires connected to original alternator output post. Move these wires to the # 1 battery post on the isolator.
5. Install new wire from alternator output post to the "A"post of isolator [use proper wire size based on alternator &/or rating].
6. Attach auxiliary battery to the # 2 battery post of isolator [for a 3 battery system attach the #3 battery to the # 3 battery post of isolator]
7. If a circuit breaker is going to be used, it should be installed next to the auxiliary battery. No circuit breaker is to be install from alternator to isolator or from isolator to main battery.
8. Connect all auxiliary loads to the auxiliary battery.
9. Reconnect the negative cable to the original battery
10. Remove the small red wire from the "Reg" terminal of alternator and move it to the "R" terminal of the isolator.
11. See wiring drawing for correct connections for your isolator part number.
12. See wiring chart to determine correct wires size on page 4.

Hehr Power Systems  
4616 Fairlane Avenue Ft Worth, TX 76119  
817/535-0284 Fax 817/531-2755 Canada 905/852-5417

## **Test Instruction for *Powerline* Motorola style Isolator using Ohmmeter**

1. Remove all wires from isolator
2. Use a needle movement Ohmmeter on RX-1 scale or digital Ohmmeter on diode scale.  
Hold red probe on terminal "A", with black probe touch terminals "B 1 " and "B2" on isolator. A good isolator will show current flow.
4. Place black probe on terminal "A" and with red probe touch terminal "BI" and "B2" on isolator. A good Isolator will not show any current flow.
5. To test "R" terminal, hold red probe on "A" terminal and black probe on "R" terminal of the isolator. A good isolator will show current flow. Hold black probe on "A" terminal and red probe on "R" terminal. A good isolator will not show any current flow.
6. Hold one probe on the aluminum heatsink, being sure there is contact. Then touch the other probe to terminals "A", "BI ", "B2". A good isolator will show no current flow.
7. NOTE: Some import Ohmmeters have the color of the leads reversed.

### **Electrical Test for *Powerline* Isolators installed with Motorola Alternators**

1. Engine not running: Terminal "BI" should read main engine battery voltage. Terminal "B2" should read auxiliary Battery voltage.
2. The "A" terminal may read 0 to 10 volts if using a digital Ohmmeter. This may be due to the capacitor in the alternator. Ground out the "A" terminal momentarily and retest, voltage reading should be 0.
3. The "R" terminal should have 0 volt reading.
4. Key on engine running: The "A" terminal should read approximately 15 volts. The "BI and "B2" terminals should read 13.8 to 14.2 volts.
5. If the "R" terminal voltage is higher than the output voltage, move the red regulator lead from the "R" terminal to the output post of the alternator: Do not use "R" terminal of isolator.

**RECOMMENDED BATTERY CABLE SIZE  
(AS A FUNCTION OF CURRENT AND LENGTH)**

**MINIMUM SIZE CABLE TO USE (AWG)**

<b>SYSTEM VOLTAGE</b>	<b>RATED OUTPUT (AMPS)</b>	<b>UP TO 5 FT.</b>	<b>5-10 FT.</b>	<b>10-15 FT.</b>	<b>15-20 FT.</b>	<b>20-25 FT.</b>	<b>25-30 FT.</b>
<b>12 VOLTS</b>	<b>0-60</b>	<b>8 AWG</b>	<b>4 AWG</b>	<b>2 AWG</b>	<b>2 AWG</b>	<b>1 AWG</b>	<b>0 AWG</b>
	<b>60-100</b>	<b>6 AWG</b>	<b>4 AWG</b>	<b>1 AWG</b>	<b>0 AWG</b>	<b>0 AWG</b>	<b>00 AWG</b>
	<b>100-150</b>	<b>4 AWG</b>	<b>2 AWG</b>	<b>0 AWG</b>	<b>00 AWG</b>	<b>00 AWG</b>	<b>000 AWG</b>
	<b>150-190</b>	<b>4 AWG</b>	<b>1 AWG</b>	<b>00 AWG</b>	<b>000 AWG</b>	<b>4/0 AWG</b>	<b>4/0 AWG</b>
	<b>190-250</b>	<b>2 AWG</b>	<b>0 AWG</b>	<b>00 AWG</b>	<b>4/0 AWG</b>	<b>4/0 AWG</b>	<b>4/0 AWG</b>
	<b>250-300</b>	<b>0 AWG</b>	<b>00 AWG</b>	<b>000 AWG</b>	<b>4/0 AWG</b>	<b>4/0 AWG</b>	<b>4/0 AWG</b>
<b>24 VOLTS</b>	<b>0-30</b>	<b>14 AWG</b>	<b>14 AWG</b>	<b>10 AWG</b>	<b>8 AWG</b>	<b>8 AWG</b>	<b>6 AWG</b>
	<b>30-50</b>	<b>12 AWG</b>	<b>10 AWG</b>	<b>8 AWG</b>	<b>6 AWG</b>	<b>6 AWG</b>	<b>4 AWG</b>
	<b>50-75</b>	<b>10 AWG</b>	<b>8 AWG</b>	<b>6 AWG</b>	<b>4 AWG</b>	<b>4 AWG</b>	<b>2 AWG</b>
	<b>75-100</b>	<b>6 AWG</b>	<b>6 AWG</b>	<b>4 AWG</b>	<b>4 AWG</b>	<b>2 AWG</b>	<b>1 AWG</b>
	<b>100- 25</b>	<b>4 AWG</b>	<b>4 AWG</b>	<b>4 AWG</b>	<b>2 AWG</b>	<b>2 AWG</b>	<b>1 AWG</b>
	<b>125-150</b>	<b>2 AWG</b>	<b>2 AWG</b>	<b>1 AWG</b>	<b>1 AWG</b>	<b>0 AWG</b>	<b>0 AWG</b>

Length of cable shown is for either POS. lead or GND. lead, not total length.

Maximum acceptable voltage drop = 0.5 volts in a 12 volt system, 1.0 volts in a 24 volt system.

**LIMITED WARRANTY**

**HEHR POWER SYSTEMS** warrants each new product against factory defects in material and workmanship for a period of time as outlined in the Warranty Period schedule (Form W 1000A-4/95). Exclusions from this warranty for damage or failure due to accident, misuse, negligence or improper installation.

Material required for repair or replacement of defective part is to be supplied at no charge on delivery of the defective part to **HEHR POWER SYSTEMS**, 4616 Fairlane Avenue, Fort Worth, Texas, 76119 or an authorized service center. The customer is responsible for all freight on returned parts.

There are no warranties, expressed or implied (including any implied warranties merchantability or fitness), which extend beyond this warranty period. The loss of use of the product, loss of time, inconvenience, commercial loss or consequential damages are not covered.

**HEHR POWER SYSTEMS** reserves the right to change the design or any product without assuming any obligation to modify any product previously manufactured.

This warranty gives you specific legal rights. You may also have other rights that vary from state to state. Some states do not allow limitations on how long an implied warranty lasts. Some states do not allow the exclusion or limitations of incidental or consequential damages. Therefore, the above limitation(s) or exclusion(s) may not apply to you.

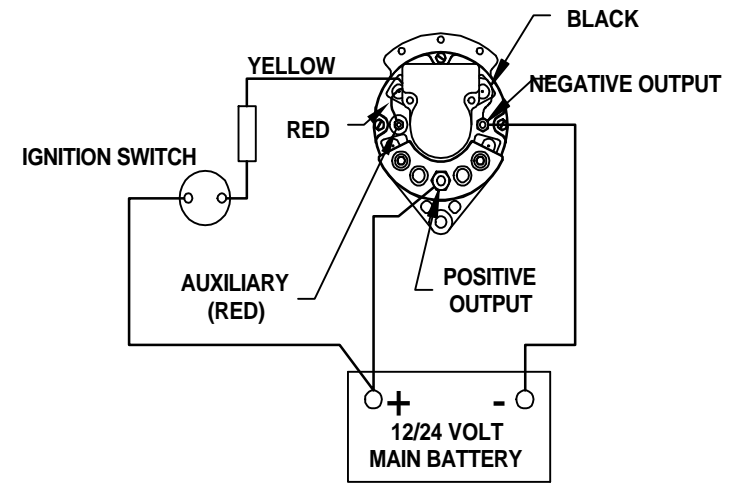
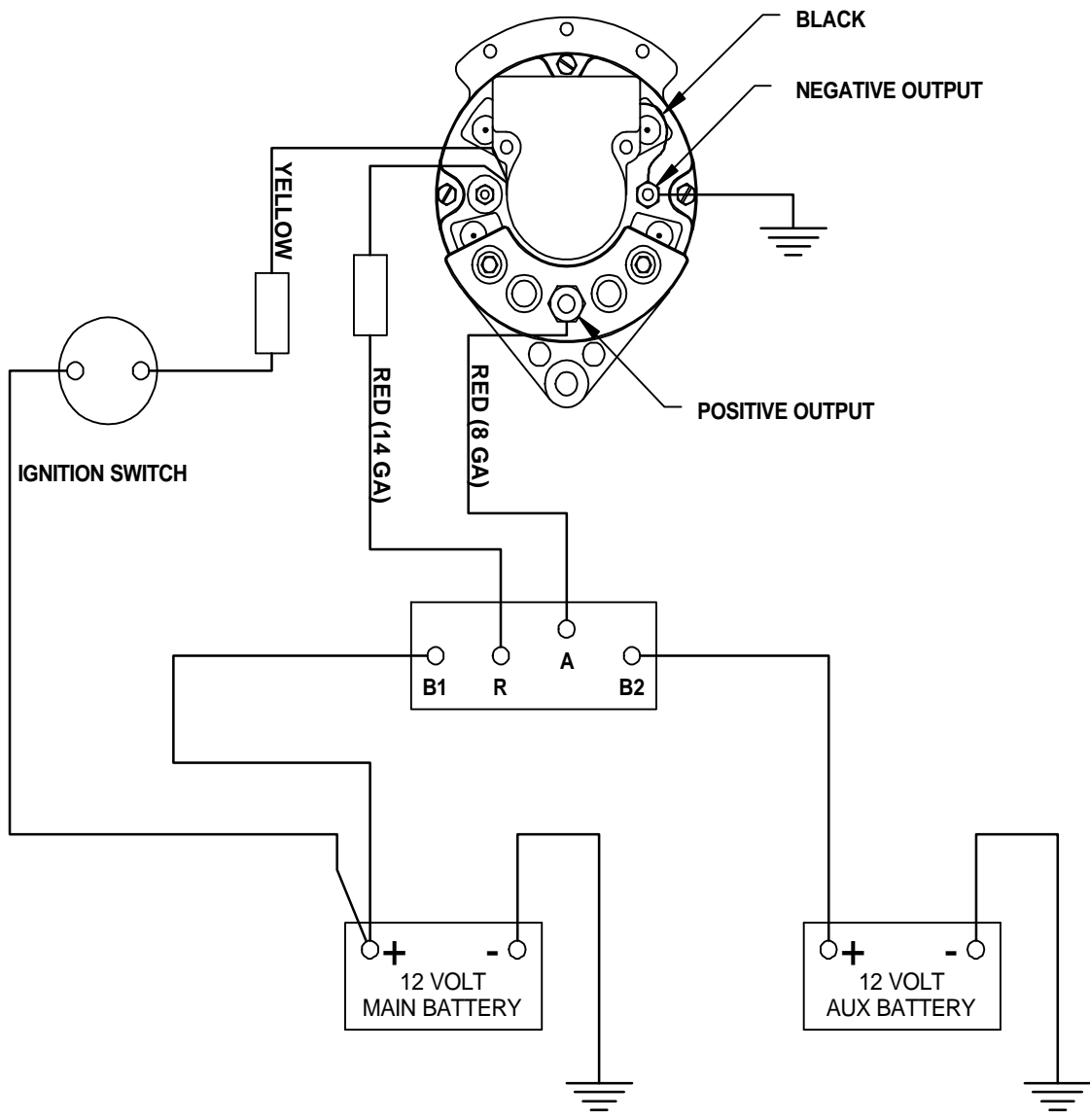

**ORIGINAL WIRING**

**MOTOROLA ISOLATOR WITH ISOLATION DIODE**

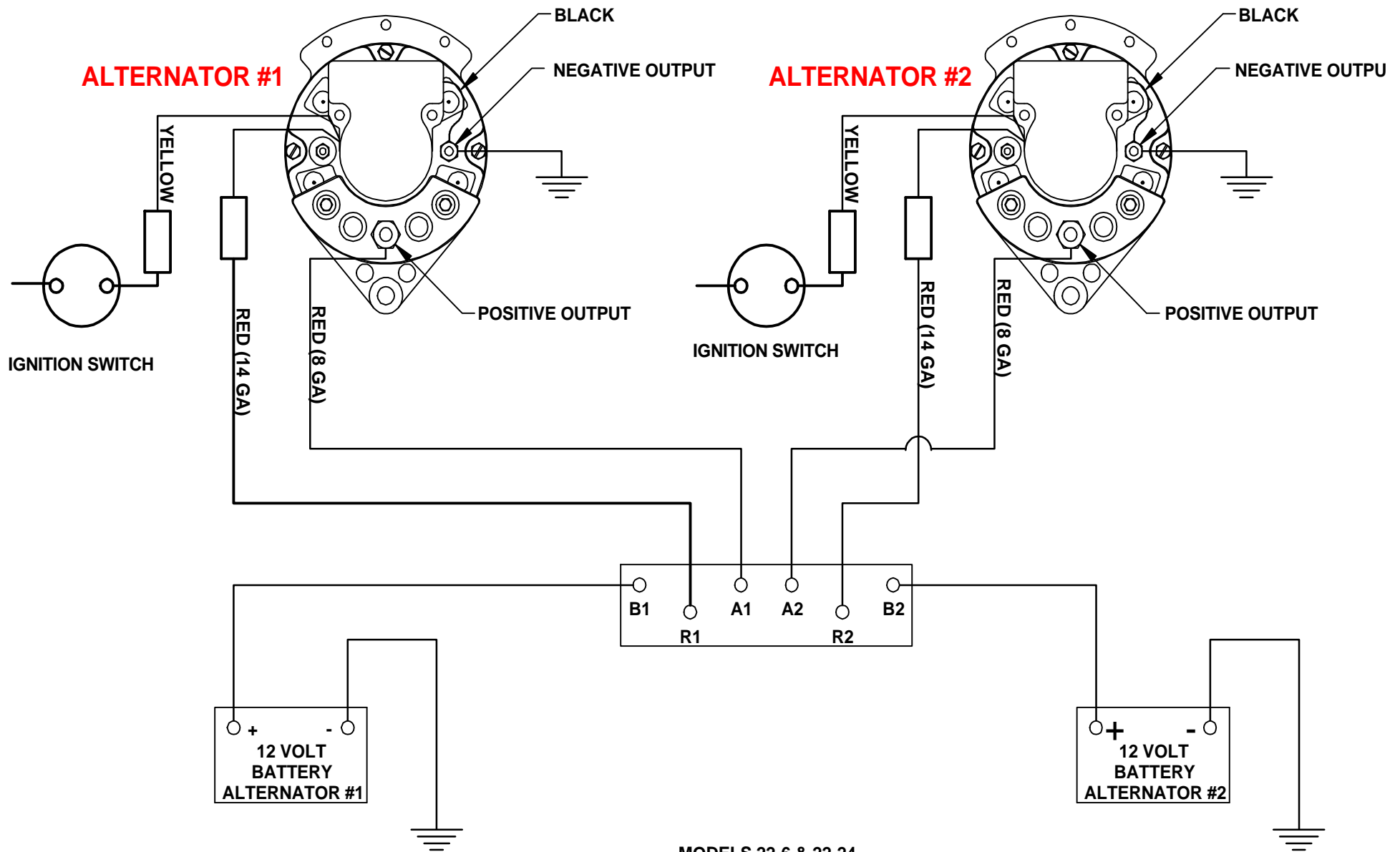

**MOTOROLA ALTERNATOR WITH ISOLATION DIODE : (2) ALTERNATOR (2) BATTERY ISOLATOR INSTALLATION**

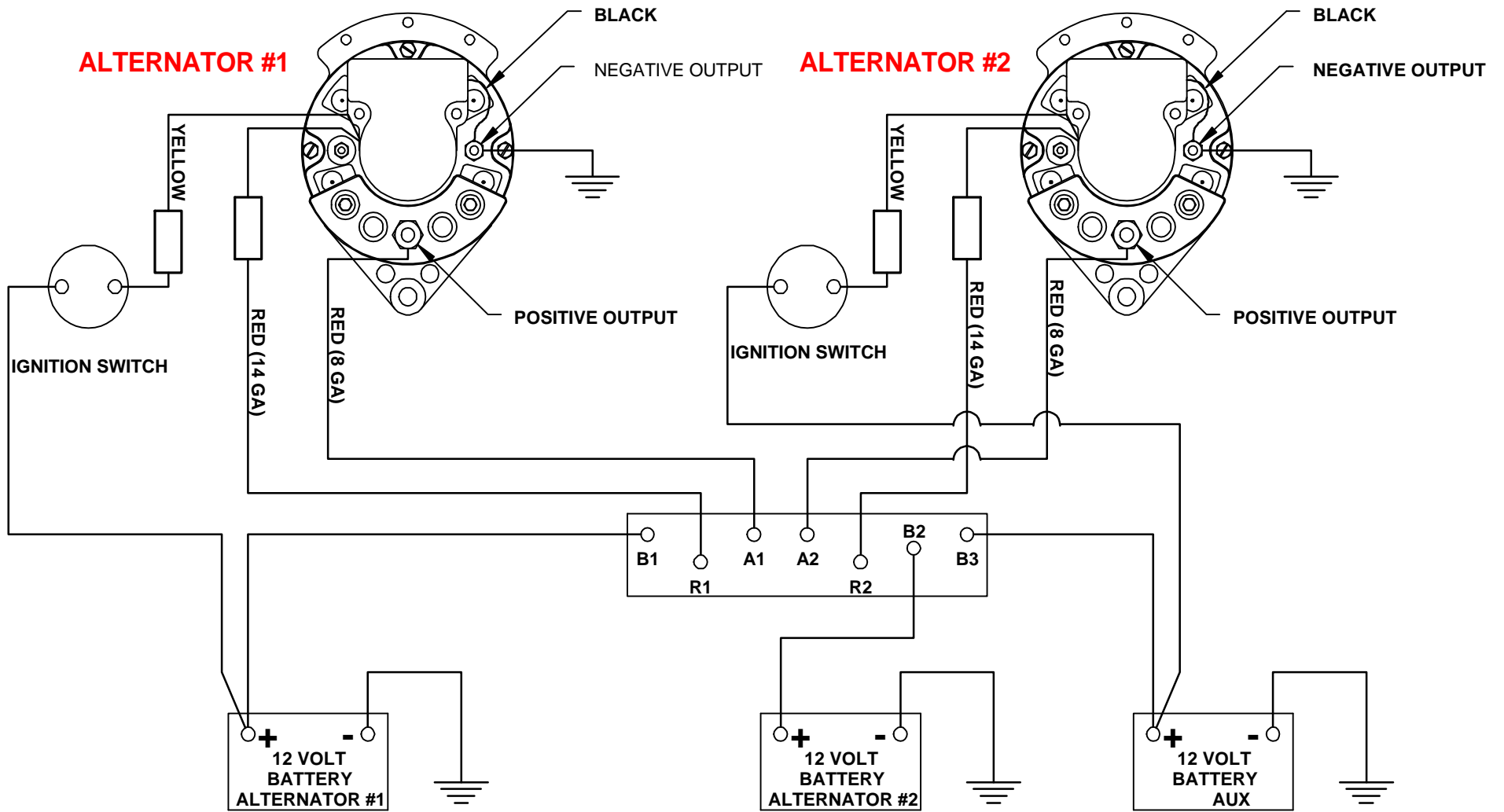

MODELS 22-8 & 22-26

**MOTOROLA ALTERNATOR WITH ISOLATION DIODE : (2) ALTERNATOR (3) BATTERY ISOLATOR INSTALLATION**